



**Privacy Vision Panel in open position**

# Vision Panels

Privacy is rightly seen as a basic human right, but can also be a potential danger to both persons and property, especially in detention centres, mental health units, hospitals, immigration centres, care centres and anywhere there is a risk of persons harming themselves.

Intastop Privacy Vision Panels allow discreet observation of the patient while still being able to monitor the situation.

.....  
Privacy Vision Panels

.....  
Integral Blind Panels

# Privacy Vision Panels

For privacy control

Standard  
etched  
open

Standard  
etched  
closed

## Easy-to-operate

Intastop Privacy Vision Panels can have dual or single lever operation on one or both sides, key operation or anti-ligature knob operation. The levers are available with an anti-bacterial coating to inhibit growth of harmful bacteria.

## Benefits

- *Increased visibility of up to 40%.*
- *Improved impact resistance (no hole in glass).*
- *Easy inter-changeability between handles.*
- *Fire Tested to BS476: Part 22 for 30, 60 and 90 minutes.*
- *UK Patent pending 10 07 981.2.*

## Colours and finishes

Fire rated and non-fire rated vision panels are available. For a more robust solution a thicker glass or a solid 6mm thick Perspex frontage is available.

Vision panels are available as rectangular 800 x 250mm or 400 x 400mm square. Other sizes available on request.

**NEW - Vision panels now available with an auto drop feature.**



**White Vision Panel**

**Black-out Vision Panel**

**Wave Design Vision Panel**

**Order details**

Order code	Description	Size (mm) H x W
VPI/1	Rectangular Vision Panel	800 x 250
VPI/2	Square Vision Panel	400 x 400

*Vision panels available in a variety of colours to brighten rooms up, coordinate with existing colour schemes and can be used to differentiate vision panel from the door.*

\* Other special sizes, solid Perspex frontage, 19mm Pyrosec C Rated glass and other glass thicknesses available to order.

# Privacy Vision Panels

(continued)

## Specification details

Non-fire rated and 30 minute fire rated panels are supplied with a 6mm toughened, 4mm, 6mm toughened arrangement. 60 minute fire rated panels are supplied with a 6mm toughened, 4mm, 7mm pyrobelite. Other glass thicknesses include 10, 12 and 19mm for a more robust option.

Available with the option of Scotshield Ultra Safety film or with a solid 6mm thick perspex frontage.

Etched strip standard is pearl with other colours and/or graphic devices available.

## Beading options



Clad beading



Hardwood beading

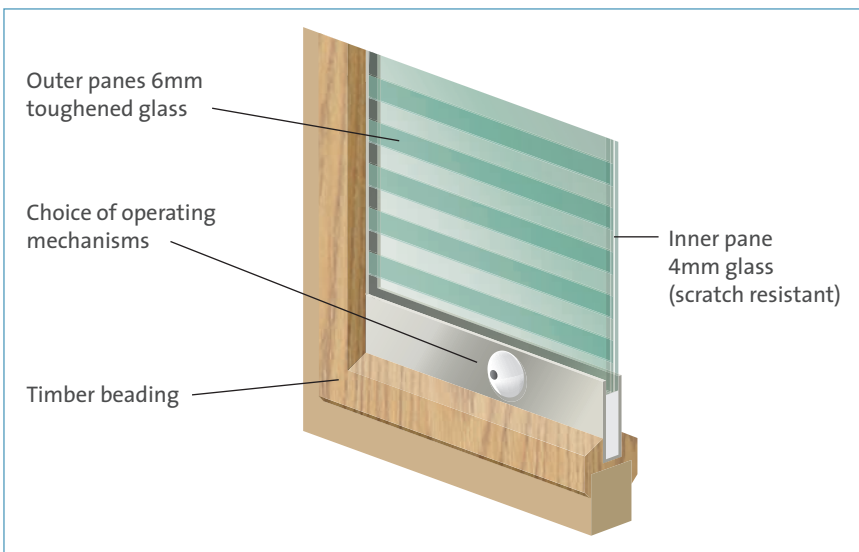

Non-fire rated and 30 minute fire rated panel

## Operating mechanisms



Lever



Anti-ligature Knob

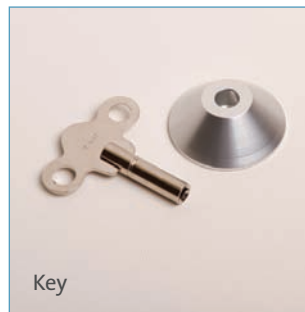

Key



Blanking Plate

# Intaview Twin Film Integral Blind Panels

The ultimate in privacy and vision control  
in any size



Large panel



Full size  
door panel  
including  
side screens

## Benefits

- Total vision, no ironmongery on base of panel.
- Greater vision, 60% visibility.
- Allows greater light infiltration.
- Fire tested to BS476: Part 22 for 30 and 60 minutes.
- Patent applied for 10 11 556.6 and 11 01 922.1.
- Tested to life span in excess of 25 years.
- Maintenance free.
- Easy to operate by only a light quarter turn.
- Easy interchange-ability of operating mechanisms.
- Removable ironmongery for flush finish.
- Improved impact resistance (no hole in glass).

# Intaview Twin Film Integral Blind Panels

(continued)



Lever operated



Rectangular Integral Blind Panel open

### Simply the widest field vision

Offering a significantly larger vision area and a far wider vertical arc vision the patent applied for Intaview Twin Film Integral Blind System is an innovation in privacy and vision control for doors within the commercial and healthcare building environments.

### More vision style and reliability

With its clean lines and modern aesthetics the Intaview Twin Film Integral Blind System suits any modern flexible interior design creating an elegant spacious aspect when the blinds are open and total privacy when closed. Less complex and more robust, the system is durable, reliable and requires no cleaning or maintenance. Simple to operate and strikingly effective it is clearly the future of vision panels.

### Colours and finishes

The Intaview System is available in the pearl colour of etched glass but other colours and or graphic devices can easily be incorporated to suit signage, branding or other applications as required.

### Standard sizes

Standard sizes for doors are 450H x 400W and 825H x 250W but other larger sizes can easily be manufactured.

#### Order details

Order code	Description	Size (mm) HxW
VIV/1	Rectangular Integral Blind Panel	825 x 250
VIV/2	Integral Blind Panel	450 x 400
VIV/3	Side Screens	1700 x 500
VIV/99	Alternative size panels*	1050 x 600 1500 x 200 1650 x 200

\*Any other sizes available

*Flexible on design and size. Able to accommodate larger panels and full size screens without compromising operation.*



### Specification details

Supplied with 6mm, 16mm cavity, 6mm arrangement of fire rated glass. Other glass thicknesses include 10, 12 and 19mm for a more robust option. Available with the option of Scotshield Ultra Safety Film or with a 6mm thick Perspex frontage.

*Intaview Integral Blinds are able to be automated (including solar powered, remote control, touch screen).*

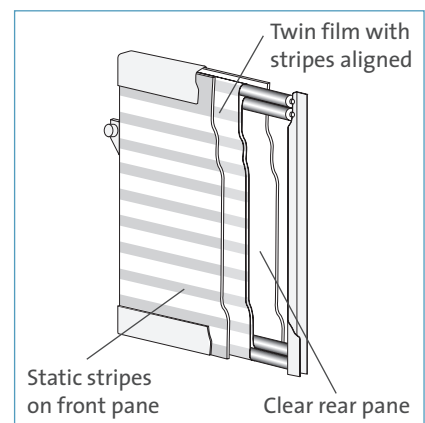

### Operating mechanisms



Knob



Lever

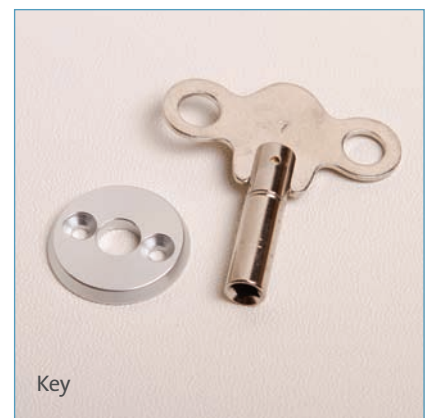

Key