

For product reference prefix : DEA / DEB

Intastop Ltd can take no responsibility for incorrect operation of Door Edge Guards that are not fitted as per directed in these instructions.

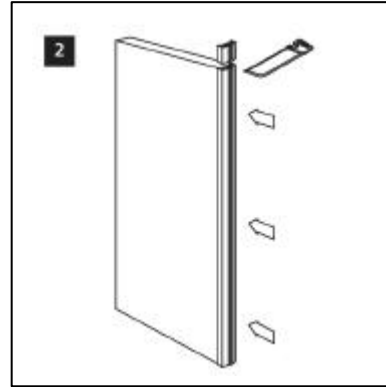
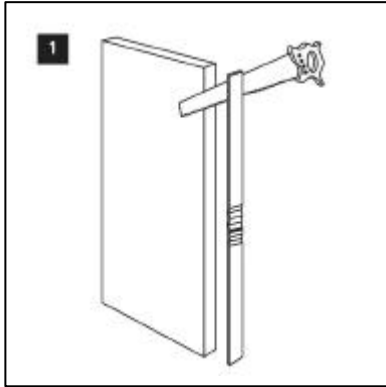

- For single or double doors, leading or hanging stiles, ensure doors are hung correctly, on suitable hinges and that the right door has been fitted. If in any doubt please contact our technical department for help
- In situ, mark off the required depth to leave a 26mm overall gap between meeting door edges. If fitting profile of a single door 13mm to be removed.
- Carefully remove door to a working area.
- Remove by means of a suitable saw or plane, the surplus door edge.

- Cut profile and brush seal lengths to match dimensions of prepared door edges
- Remove all sharp edges by means of a line file or other suitable fine abrasive
- Remove the brush seal

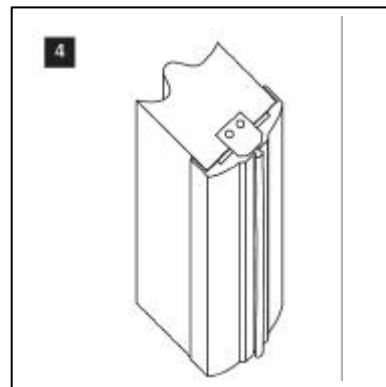
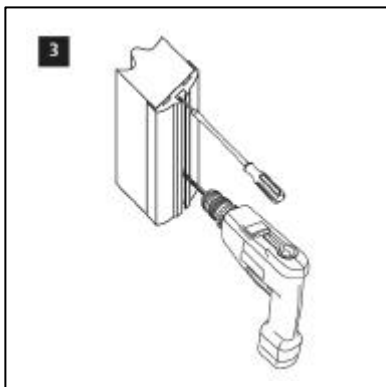

- Fix the profile into position using the 12, 1 inch screws provided. (leave some fixing holes free for the pinning of the brushseal (see below).
- Cut the Brushseal into 200mm Sections, remove backing tape and slide into the profile. Finally Pin the brushseal along the length of the profile to prevent unwanted removal.

- Fasten brush retaining plates at top and bottom of door with the 4, 3/4 inch screws provided
- Re-hang door

FIXING INSTRUCTION

In case of technical queries please contact: Intastop Ltd, Holly House, Kelham St. Ind. Est, Doncaster, South Yorkshire DN1 3QZ
Tel :01302 364666 Fax: 01302 364777
E-mail: technical@intastop.com
Internet: www.intastop.com